

Reangularity, Semangularity, and Ideality

By

Dr. Michael S. Slocum

Catherine Lundberg

Katrina Walter

Abstract:

Using Axiomatic design to create a robust disposable self-heating chafing dish for use by consumers. This paper compares the standard combustible fuel disposable chafing system with a self-heating disposable chafing system. The results from this comparison are utilized for further development of the product.

Axiomatic Design Axioms

1. *The Independence Axiom* – Maintain the independence of FRs
2. *The Information Axiom* – Minimize the information content of the design
 - a. The information content (IC) is calculated by :

$$IC = \log \left(\frac{\text{total \# of observations}}{\text{total \# of acceptable observations}} \right)$$

Design Matrix

Standard Combustible Fuel Disposable Chafing System

Functional Requirement	Design Parameter
1.0 Hold Food	DP1.1 Aluminum food pan(s) DP1.2 Frame to hold food pan(s)
2.0 Maintains food 2.1 $\bar{T} \geq T_{i+30 \text{ min}}$ 2.2 $t \geq 2 \text{ hours}$	DP2.1 Combustible Fuel Source DP2.2 Water Pan
3.0 Inexpensive Remove as constraint (RAC) RAC RAC	DP3.1 Aluminum (standard) food pan(s) DP3.2 Fuel (standard) is inexpensive DP3.3 Frame design is simple DP3.4 Assembly is basic DP3.5 Low weight system (reduces shipping cost)
4.0 Portability RAC	DP4.1 Same as DP3.5 DP4.2 Handles for carrying
5.0 Manufacturability RAC	DP5.1 Most assembly is pick and place DP5.2 Use of standard (off the shelf) items
6.0 Easy to use RAC	DP6.1 3-step activation

Design Matrix to identify coupling within the design. Utilizing this equation:

$$\{FR\} = [A]\{DP\} \quad FR_i = \sum_j A_{ij} DP_j \quad \text{Equation 1.0}$$

Design Matrix for a Disposable Combustible Chafing System

DP/FR	FR1.0	FR2.1	FR2.2	FR3.0	FR4.0	FR5.0	FR6.0
DP1.1	X	X	X	X	X	X	X
DP1.2	X	O	O	X	X	X	X
DP2.1	O	X	X	X	X	O	X
DP2.2	O	X	X	X	O	O	X
DP3.1	X	X	X	X	O	X	O
DP3.2	O	O	O	X	O	O	O
DP3.3	X	O	O	X	O	X	X
DP3.4	O	O	O	X	O	X	X
DP3.5	O	O	O	X	X	X	X
DP4.1	O	O	O	X	X	X	X
DP4.2	O	O	O	O	X	O	X
DP5.1	O	O	O	X	O	X	O
DP5.2	X	O	O	X	O	X	X
DP6.1	O	O	O	O	O	O	X

Graphical Representation of Coupling by FR Group

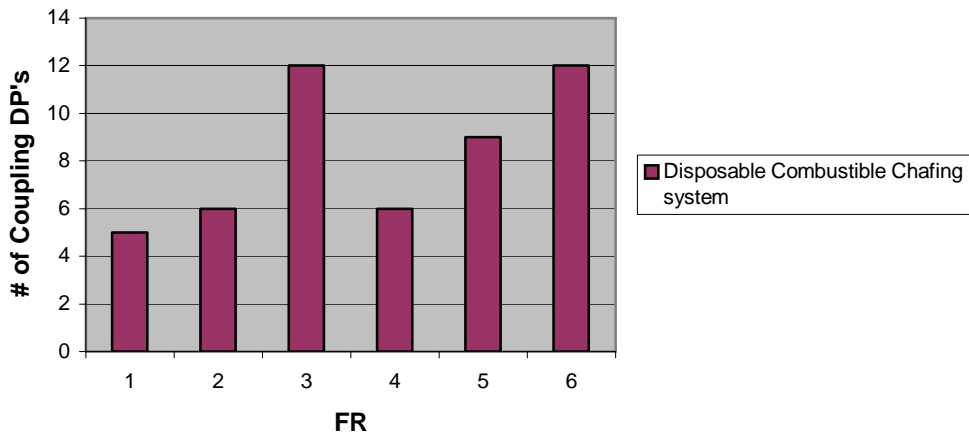

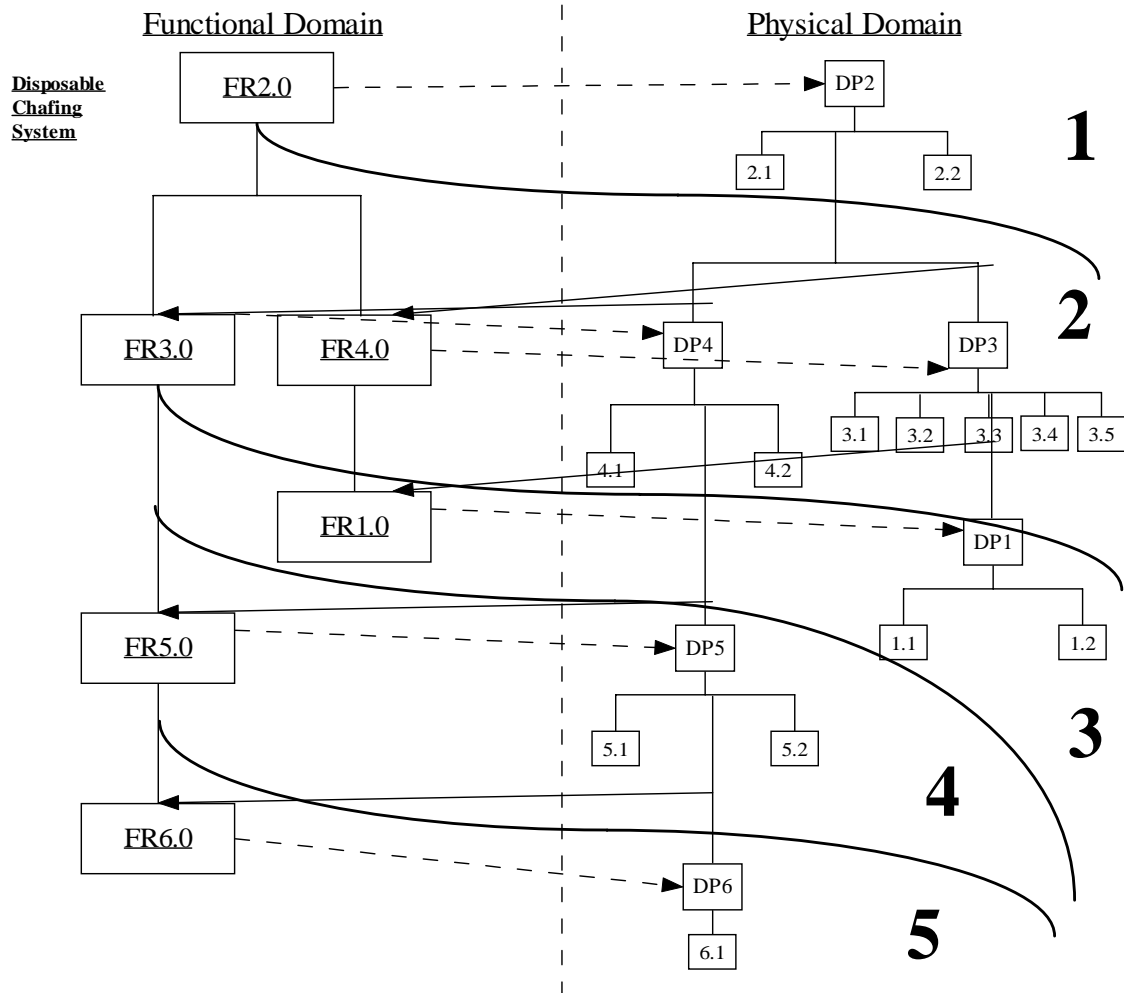

- This flowchart outlines the design progress
- The DP's from the previous FR feeds into the next FR's
- Analyze the design at each of the 5 levels.

Self-heating Disposable Chafing System

Functional Requirement	Design Parameter
1.0 Hold Food	DP1.1 Aluminum food pan(s) DP1.2 Supported by SCRB
2.0 Maintains food 2.1 $\bar{T} \geq T_{i+30\text{min}}$ 2.2 $t \geq 2$ hours	DP2.1 Exothermic Chemical Reaction DP2.2 Surface contact between food tray and SCRB DP2.3 Insulation internal to SCRB DP2.4 Food pan lid
3.0 Inexpensive RAC	DP3.1 Materials are inexpensive DP3.2 Food pans are off the shelf
4.0 Portability	DP4.1 Outer tray has handles DP4.2 Fully integrated system
5.0 Manufacturability RAC	DP5.1 Utilizing vacuum form and injection molding DP5.2 Basic mfg/assembly process
6.0 Easy to use RAC	DP6.1 2-step activation

Design Matrix for the Self-heating Disposable Chafing System

DP/FR	FR1.0	FR2.1	FR2.2	FR3.0	FR4.0	FR5.0	FR6.0
DP1.1	X	X	X	X	O	X	O
DP1.2	X	X	X	O	O	X	O
DP2.1	O	X	X	O	X	O	X
DP2.2	O	X	X	O	O	O	O
DP2.3	O	X	X	X	O	X	O
DP2.4	O	X	X	X	X	X	X
DP3.1	O	O	O	X	O	O	O
DP3.2	X	O	O	X	O	X	X
DP4.1	O	O	O	X	X	O	X
DP4.2	O	X	X	O	X	O	X
DP5.1	O	O	O	X	O	X	O
DP5.2	O	O	O	X	O	X	O
DP6.1	O	O	O	O	O	O	X

Graphical Representation of Coupling by FR Group

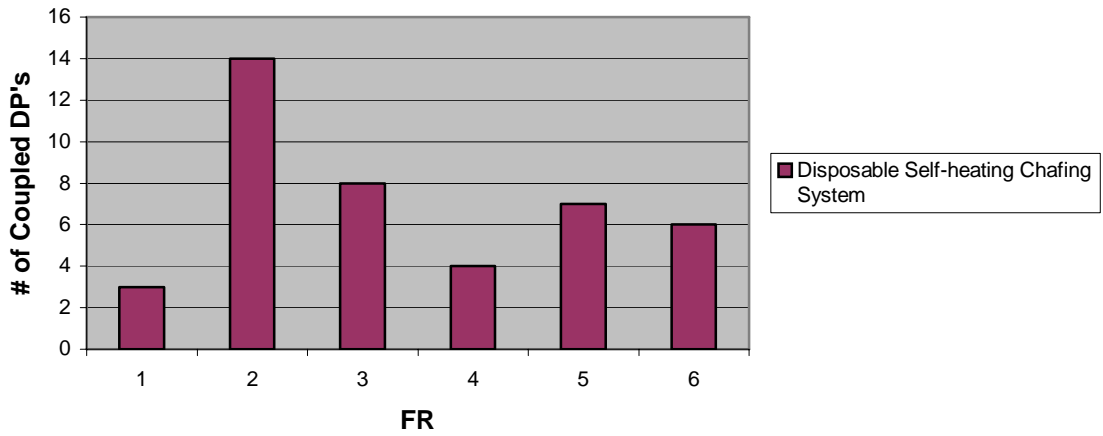

Graphical Representation of Coupling DP's by FR Group

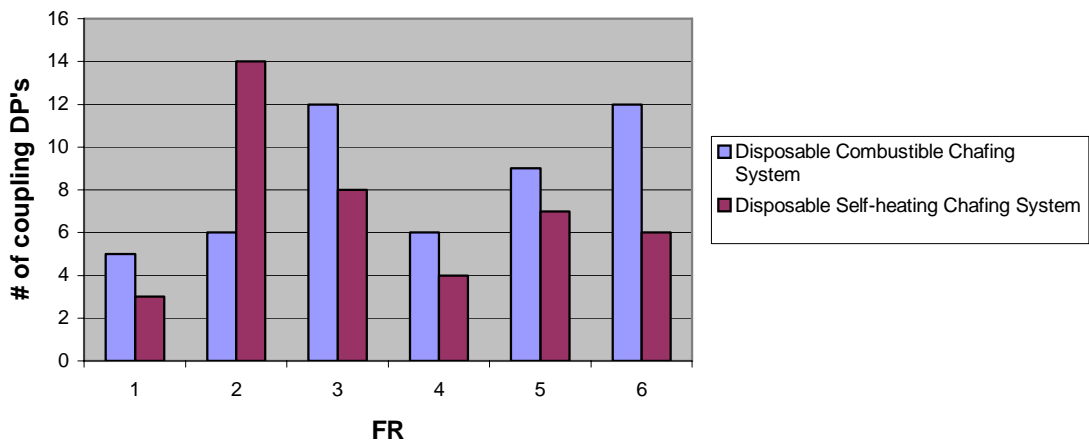

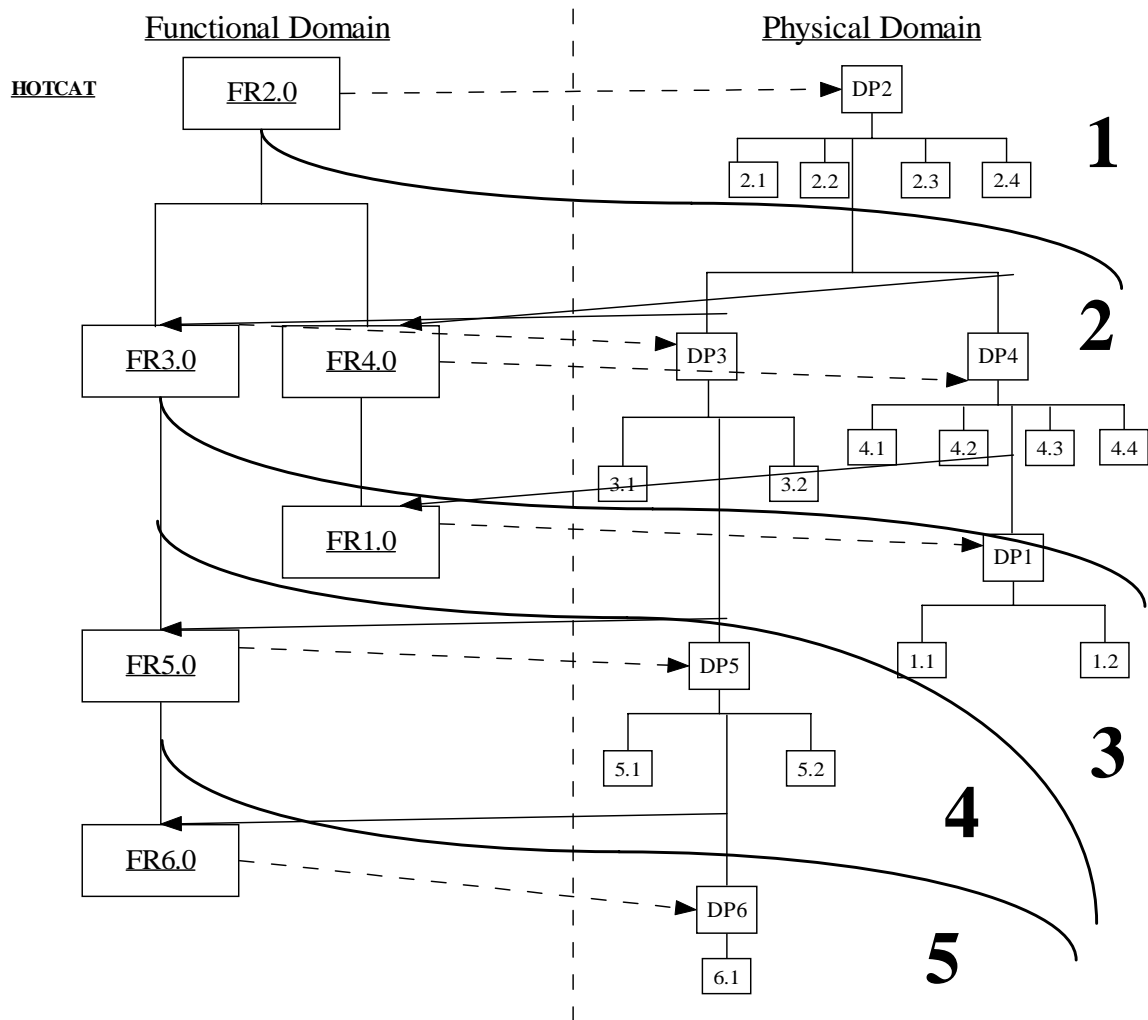

Information Content (Partial)

The partial information content was calculated utilizing the above described equation and data from Buffet Test #1 and #2. The rating was considered acceptable if the food was rated between 2 and 4 (rating scale was 1-5, cold to hot).

For the Standard Combustible System

$$IC_{Partial} = \log\left(\frac{187}{136}\right) = 0.138$$

For the Self-heating Disposable Chafing System

$$IC_{Partial} = \log\left(\frac{182}{164}\right) = 0.045$$

Removing FR's 3.0, 5.0, and 6.0

FR's 3.0, 5.0, and 6.0 could be considered system constraints instead of FR's. The above analysis is repeated after the removal of these FR's. The *new* FR's are as follows:

Disposable Combustible Fuel Chafing System

Functional Requirement	Design Parameter
1.0 Hold Food	DP1.1 Aluminum food pan(s) DP1.2 Frame to hold food pan(s)
2.0 Maintains food 2.1 $\bar{T} \geq T_{i+30 \text{ min}}$ 2.2 $t \geq 2 \text{ hours}$	DP2.1 Combustible Fuel Source DP2.2 Water Pan
3.0 Portability	DP3.1 Low weight of system DP3.2 Handles for carrying

Design Matrix for a Disposable Combustible Chafing System

DP/FR	FR1.0	FR2.1	FR2.2	FR3.0
DP1.1	X	X	X	X
DP1.2	X	O	O	X
DP2.1	O	X	X	X
DP2.2	O	X	X	O
DP3.1	O	O	O	X
DP3.2	O	O	O	X

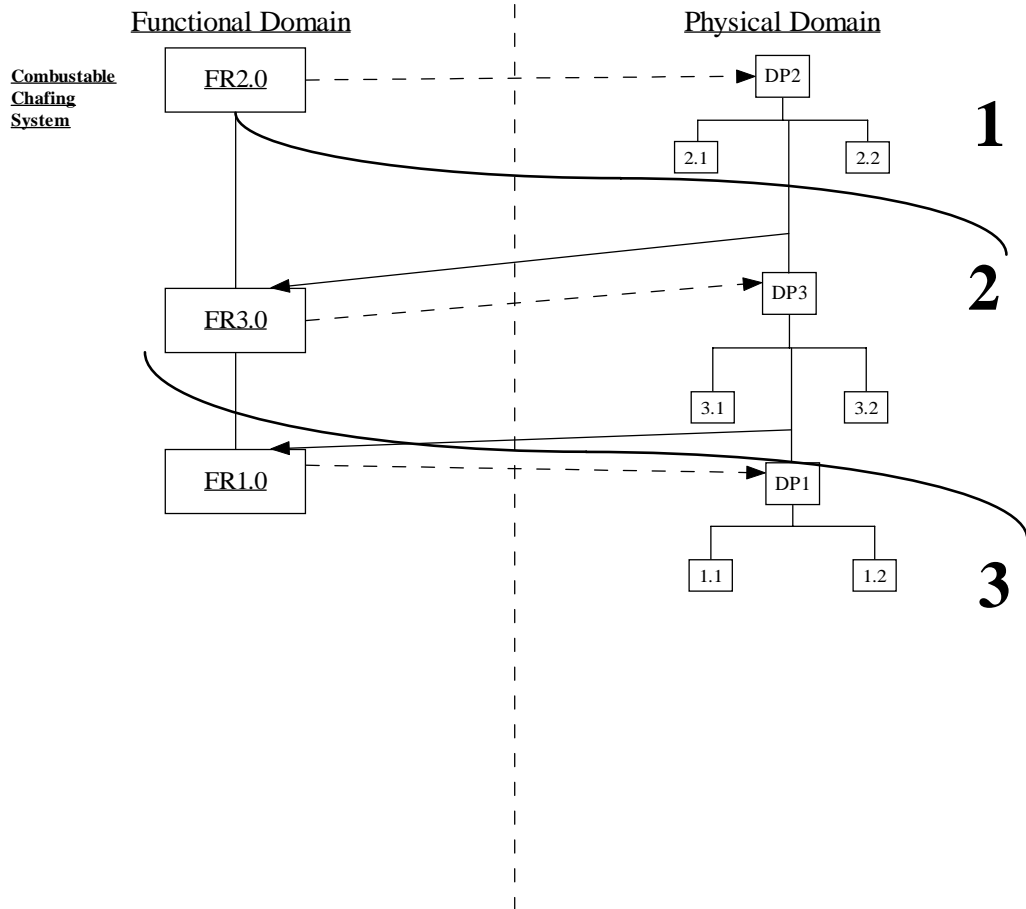

Self-heating Disposable Chafing System

Functional Requirement	Design Parameter	Status	Action
1.0 Hold Food	DP1.1 Aluminum food pan(s) DP1.2 Supported by SCRБ	Redundant	
2.0 Maintains food 2.1 $\bar{T} \geq T_{i+30 \text{ min}}$ 2.2 $t \geq 2 \text{ hours}$	DP2.1 Exothermic Chemical Reaction DP2.2 Surface contact between food tray and SCRБ DP2.3 Insulation internal to SCRБ DP2.4 Food pan lid	Redundant Redundant	Eliminate insulation Eliminate lid
3.0 Portability	DP3.1 Outer tray has handles DP3.2 Fully integrated system	Redundant	

Design Matrix for the Self-heating Disposable Chafing System

DP/FR	FR1.0	FR2.1	FR2.2	FR3.0
DP1.1	X	X	X	O
DP1.2	X	X	X	O
DP2.1	O	X	X	X
DP2.2	O	X	X	O
DP2.3	O	X	X	O
DP2.4	O	X	X	X
DP3.1	O	O	O	X
DP3.2	O	X	X	X

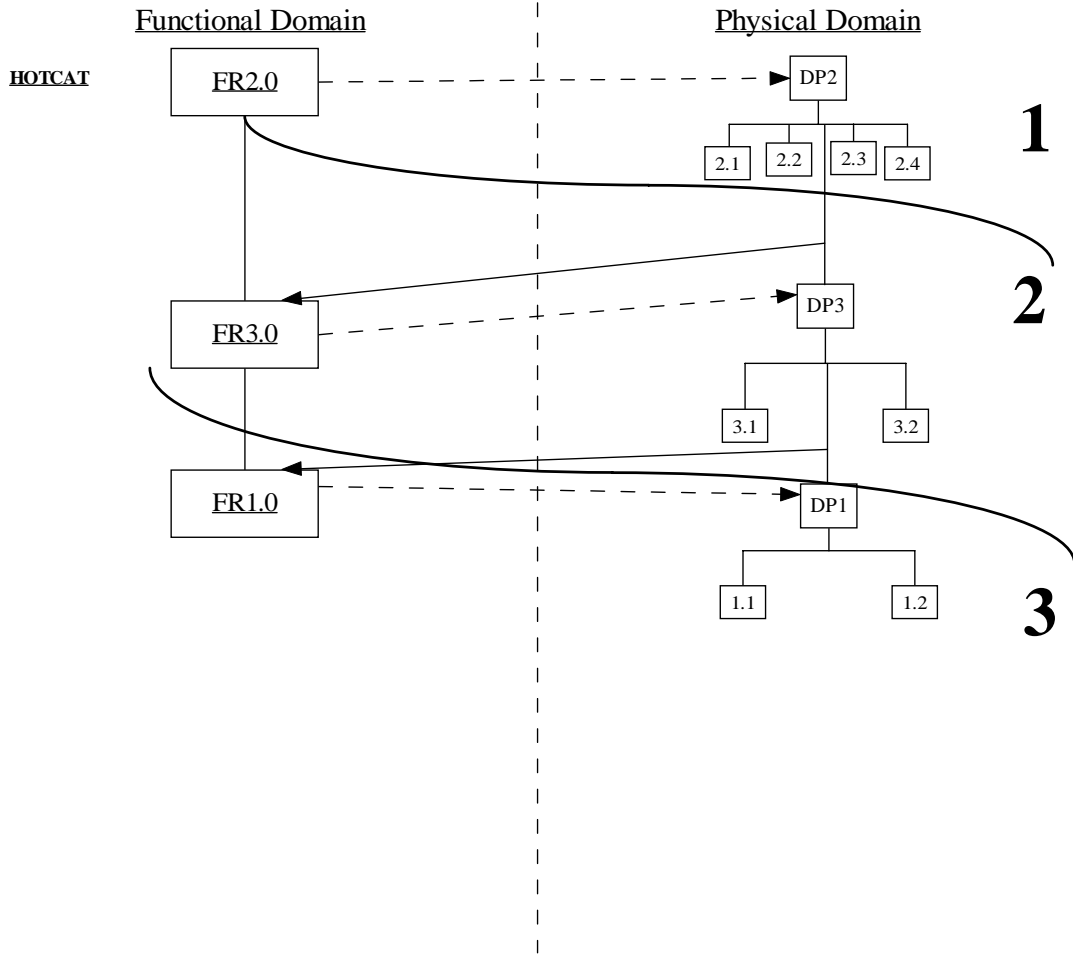

Graphical Representation of Coupling of DP's by FR

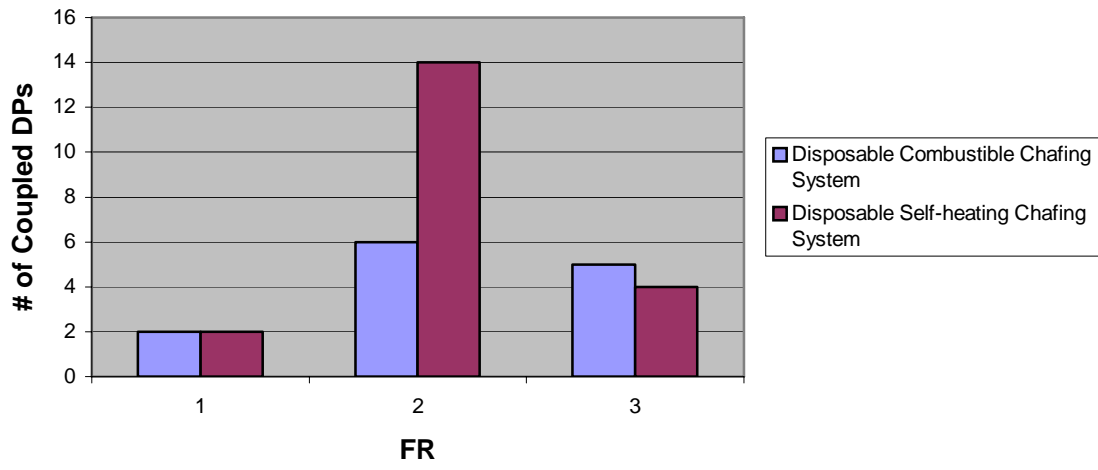

Our design has $FR < DP$'s. This means our design is redundant or coupled. This means it is over designed and probably costs too much. To reduce the design to a simpler design we will:

1. Delete the lid (DP 2.4)
2. Injection mold the polypropylene SCRB which may reduce or eliminate the insulation (DP2.3)

Quantitative Methods for Determining Coupling - Reangularity and Semangularity

Semangularity is a value that, when equal to unity, 1, then the design is uncoupled providing the reangularity is also equal to unity, 1. Semangularity, S , is defined by the following:

$$S = \prod_{j=1}^n \frac{|A_{jj}|}{\left(\sum_{k=1}^n A_{kj}^2\right)^{1/2}}$$

Reangularity, R is a value that has an inverse relationship to coupling (ie as reangularity decreases, coupling increases). If R is 0, the design is completely coupled. If R and S are unity, 1 then the design is uncoupled. Reangularity is defined by the following:

$$R = \sin \theta = \left(1 - \cos^2 \theta\right)^{1/2}$$

For the n^{th} dimensional case:

$$R = \prod_{\substack{i=1, n-1 \\ j=1, n}} \left(1 - \frac{\sum_{k=1}^n \Delta_{ki} \Delta_{kj}}{\left(\sum_{k=1}^n \Delta_{ki}^2\right) \left(\sum_{k=1}^n \Delta_{kj}^2\right)} \right)^{1/2}$$

This information combined with the design equation 1.0 and corresponding matrix to create isotherms utilizing the following methodology outlined in the following 2-dimensional example:

$$[FR] = [A][DP] \quad \text{Equation 1}$$

For the 2 dimensional case:

$$\begin{Bmatrix} FR_1 \\ FR_2 \end{Bmatrix} = \begin{bmatrix} A_{11} & A_{12} \\ A_{21} & A_{22} \end{bmatrix} \begin{Bmatrix} DP_1 \\ DP_2 \end{Bmatrix} = \begin{Bmatrix} A_{11} \\ A_{12} \end{Bmatrix} DP_1 + \begin{Bmatrix} A_{21} \\ A_{22} \end{Bmatrix} DP_2 \quad \text{OR}$$

$$FR = C_1 DP_1 + C_2 DP_2 = FR_{1j} + FR_{2j}$$

$$\text{Vector } C_k \text{ are: } C_1 = \begin{Bmatrix} A_{11} \\ A_{12} \end{Bmatrix}; \quad C_2 = \begin{Bmatrix} A_{21} \\ A_{22} \end{Bmatrix}$$

$$\cos \theta = \frac{C_1 \bullet C_2}{|C_1| \bullet |C_2|}$$

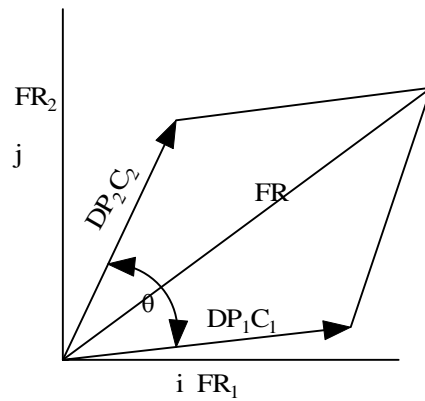

p-diagram

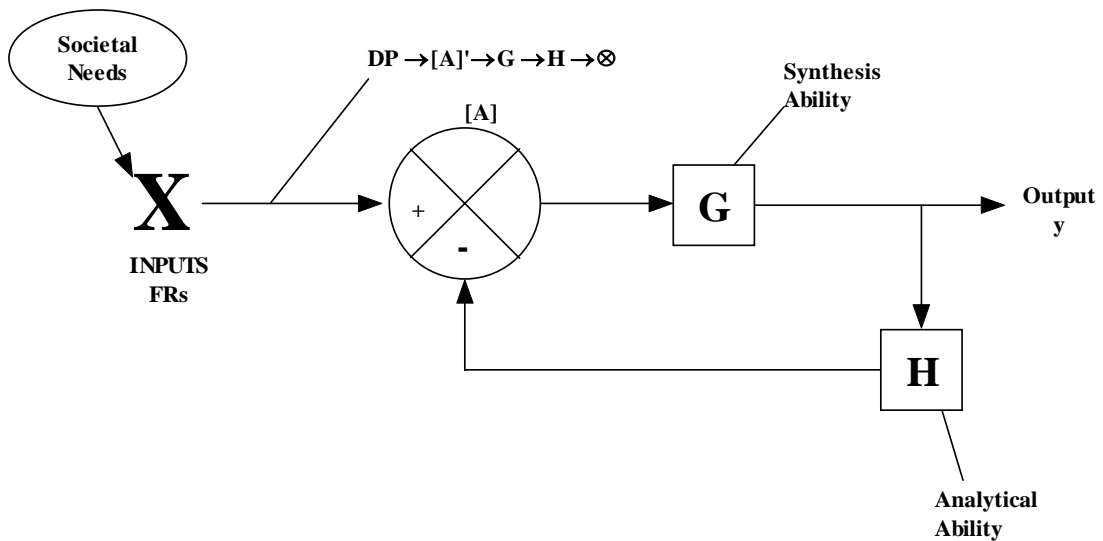
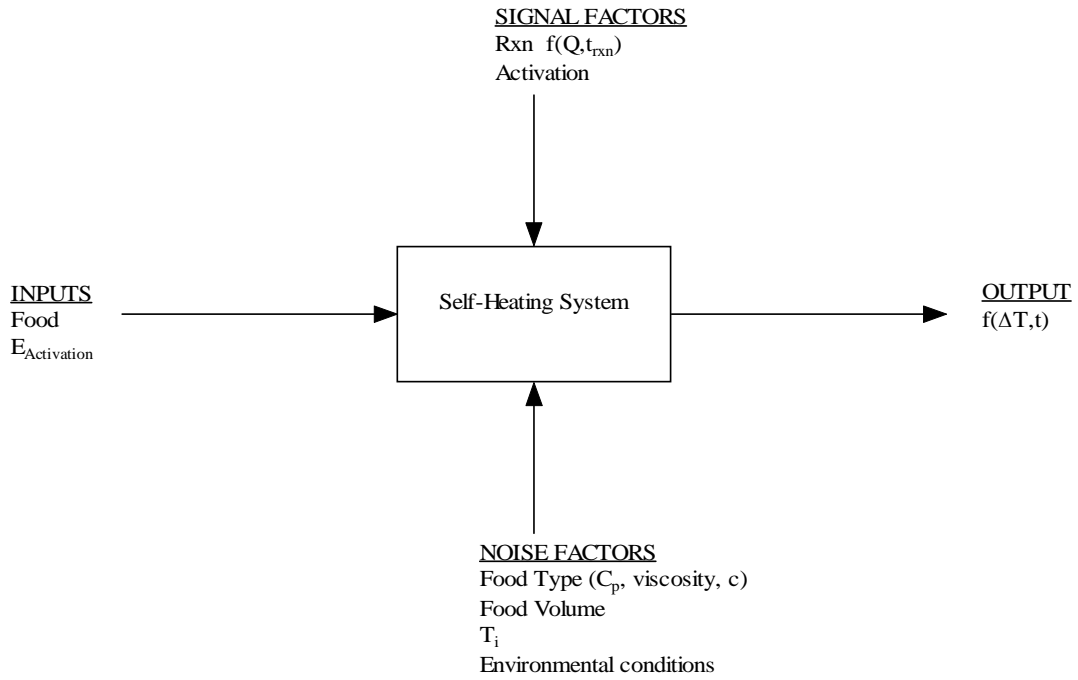

$$\frac{y}{x} = \frac{G}{1 + GH} \approx \frac{G}{GH};$$

$$H^{-1} \text{ for } GH \gg 1$$

$$FR = \sum_{l=1}^h [(l + l' + l'' + \dots + l^h)] = DP; \text{ where } l \text{ is each iteration of the } [\otimes \rightarrow G \rightarrow H] \text{ cycle}$$

Robustness

$$\sigma^2 = \text{variance} = \frac{1}{n-1} \sum_{p=1}^n (FR_j^p - \overline{FR}_i)^2$$

$$\overline{FR}_i = m = \frac{1}{n} \sum_{p=1}^n FR_i^p$$

Taguchi

$$SN = 10 \log \left(\frac{m^2}{\sigma^2} \right); \text{ the higher the better}$$

Decibels, dB

The FR's are dimensionless because a log normalization of the terms is performed.

Bias - Aiming for a 0 value

$$b = (FR_i)_o - FR = (FR_i)_0 - m$$

Functional Requirements

Functional Requirements	Design Parameters
FR 1.0 Holds Food	DP 1.1 Aluminum Food Pan
FR 2.0 Maintain Food Temperature	DP 2.1 Exothermic Chemical Reaction (SCRB)
FR 3.0 Portability	DP3.1 Fully integrated system with handles
Constraints	
C.1 Inexpensive	
C.2 Manufacturable	
C.3 Easy to Use	

Design Matrix

$$\{FR\} = [A]\{DP\}$$

$$\begin{Bmatrix} FR1.0 \\ FR2.0 \\ FR3.0 \end{Bmatrix} = \begin{bmatrix} A_{11} & 0 & 0 \\ A_{21} & A_{22} & 0 \\ 0 & 0 & A_{33} \end{bmatrix} \begin{Bmatrix} DP1.1 \\ DP2.1 \\ DP3.1 \end{Bmatrix} \text{ Coupled Design}$$

$$FR_1 = 2L$$

$$DP_{1,1} = (l * w * h) = 2L$$

$$FR_2 \geq 60^\circ C$$

$$DP_{2,1} = 168,000cal$$

$$FR_3 \leq 5500g$$

$$DP_{3,1} = \left(M_t = \frac{2}{9} b^2 h S_v \right) (h > b);$$

$$\text{where, } S_v = \text{vertical shear} = S_{vMax} = \frac{3}{2} \frac{V}{bh}$$

∴

$$A_{11} = \{2L = l * w * h\}$$

$$A_{21} = 33 \frac{mL}{^\circ C \Delta T}$$

$$A_{22} = 2800 \frac{cal}{^\circ C \Delta T}$$

$$A_{33} = \{M_t > 5500g\}$$

Isograms

$$FR_{3,1} = C_3 DP_3 + C_1 DP_1$$

$$C_1 = \begin{Bmatrix} A_{11} \\ 0 \\ 0 \end{Bmatrix} = \begin{Bmatrix} 2L = lwh \\ 0 \\ 0 \end{Bmatrix} \quad C_3 = \begin{Bmatrix} 0 \\ 0 \\ A_{33} \end{Bmatrix} = \begin{Bmatrix} 0 \\ 0 \\ M_t > 5500g \end{Bmatrix}$$

$$\cos \theta = \frac{C_1 \bullet C_3}{|C_1| \bullet |C_3|} = \frac{(A_{11} * 0) + (0 * 0) + (0 * A_{33})}{(A_{11}^2 + 0^2 + 0^2)^{1/2} * (0^2 + 0^2 + A_{33}^2)^{1/2}} = \frac{0}{A_{11} * A_{33}} = 0$$

$$\theta = 90^\circ$$

$$\alpha = \tan^{-1} \left(\frac{-A_{13}}{A_{33}} \right) = \tan^{-1} \left(\frac{-0}{A_{33}} \right) = 0^\circ$$

$$\alpha' = \tan^{-1} \left(\frac{A_{31}}{A_{11}} \right) = \tan^{-1} \left(\frac{0}{A_{11}} \right) = 0^\circ$$

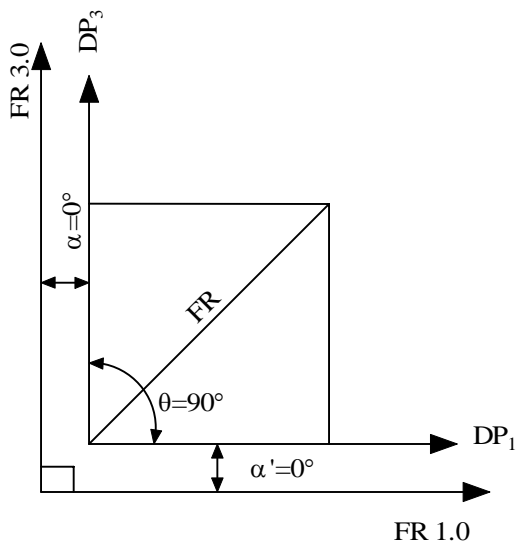

$$FR_{2,1} = C_2 DP_2 + C_1 DP_1$$

$$C_1 = \begin{Bmatrix} A_{11} \\ 0 \\ 0 \end{Bmatrix} = \begin{Bmatrix} 2L = lwh \\ 0 \\ 0 \end{Bmatrix} \quad C_2 = \begin{Bmatrix} A_{21} \\ A_{22} \\ 0 \end{Bmatrix} = \begin{Bmatrix} 33 \frac{mL}{^\circ C \Delta T} \\ 2800 \frac{cal}{^\circ C \Delta T} \\ 0 \end{Bmatrix}$$

$$\cos \theta = \frac{C_1 \bullet C_2}{|C_1| \bullet |C_2|} = \frac{(A_{11} * A_{21}) + (0 * 0) + (0 * A_{22})}{(A_{11}^2 + 0^2 + 0^2)^{1/2} * (A_{21}^2 + 0^2 + A_{22}^2)^{1/2}} = \frac{A_{11} * A_{21}}{(A_{21}^2 + A_{22}^2)^{1/2} * A_{11}} \neq 0$$

To solve you must use this relationship

$$R = \cos(\alpha - \alpha') = \sin \theta$$

$$\alpha = \tan^{-1} \left(\frac{-A_{12}}{A_{22}} \right) = \tan^{-1} \left(\frac{-0}{A_{22}} \right) = 0^\circ$$

$$\alpha' = \tan^{-1} \left(\frac{A_{21}}{A_{11}} \right) = \tan^{-1} \left(\frac{33 \frac{mL}{^\circ C \Delta T}}{2000 mL} \right) = 1^\circ$$

$$R = \cos(0 - 1) = \cos(-1) = 0.9998$$

$$\sin \theta = 0.9998$$

$$\theta = 89^\circ$$

$$\cos(89^\circ) = 0.017$$

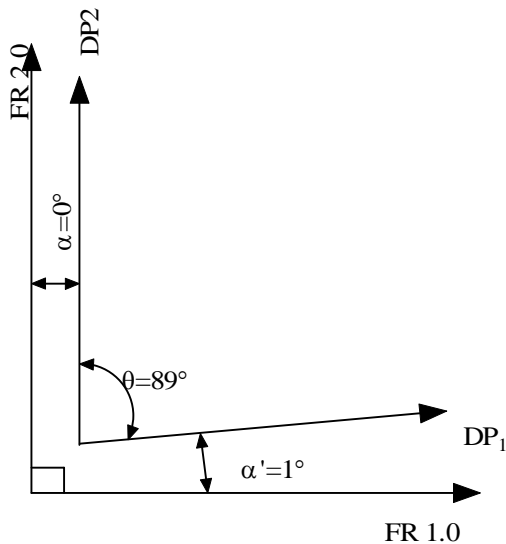

$$FR_{3,2} = C_3 DP_3 + C_2 DP_2$$

$$C_2 = \begin{Bmatrix} A_{21} \\ A_{22} \\ 0 \end{Bmatrix} = \begin{Bmatrix} 33 \frac{mL}{^\circ C \Delta T} \\ 2800 \frac{cal}{^\circ C \Delta T} \\ 0 \end{Bmatrix} \quad C_3 = \begin{Bmatrix} 0 \\ 0 \\ A_{33} \end{Bmatrix} = \begin{Bmatrix} 0 \\ 0 \\ M_t > 5500g \end{Bmatrix}$$

$$\cos \theta = \frac{C_2 \cdot C_3}{|C_2| \cdot |C_3|} = \frac{(A_{21} * 0) + (A_{22} * 0) + (0 * A_{33})}{(A_{21}^2 + A_{22}^2 + 0^2)^{1/2} * (0^2 + 0^2 + A_{33}^2)^{1/2}} = \frac{0}{(A_{21}^2 + A_{22}^2)^{1/2} * A_{33}} = 0$$

$$\theta = 90^\circ$$

$$\alpha = \tan^{-1} \left(\frac{-A_{23}}{A_{33}} \right) = \tan^{-1} \left(\frac{-0}{A_{33}} \right) = 0^\circ$$

$$\alpha' = \tan^{-1} \left(\frac{A_{32}}{A_{22}} \right) = \tan^{-1} \left(\frac{0}{A_{22}} \right) = 0^\circ$$

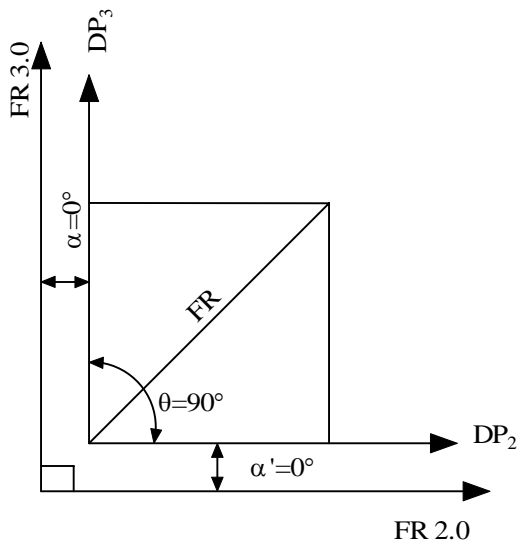

Semangularity, S

$$\begin{aligned}
 S &= \prod_{j=1}^n \left(\frac{|A_{jj}|}{A_{j1}^2 + A_{j2}^2 + A_{j3}^2} \right) = \left(\frac{|A_{11}|}{A_{11}^2 + A_{12}^2 + A_{13}^2} \right) \left(\frac{|A_{22}|}{A_{21}^2 + A_{22}^2 + A_{23}^2} \right) \left(\frac{|A_{33}|}{A_{31}^2 + A_{32}^2 + A_{33}^2} \right) \\
 &= \left\{ \frac{|\{2L=lwh\}|}{\left(\{2L=lwh\}^2 + 0^2 + 0^2 \right)^{1/2}} \right\} \left\{ \frac{\left| 2800 \frac{cal}{^\circ C \Delta T} \right|}{\left[\left(33 \frac{mL}{^\circ C \Delta T} \right)^2 + \left(2800 \frac{cal}{^\circ C \Delta T} \right)^2 + 0^2 \right]} \right\} \left\{ \frac{|M_t > 5500g|}{\left(0^2 + 0^2 + (M_t > 5500g)^2 \right)^{1/2}} \right\} \\
 &= 1^* \left\{ \frac{\left| 2800 \frac{cal}{^\circ C \Delta T} \right|}{\left[\left(33 \frac{mL}{^\circ C \Delta T} \right)^2 + \left(2800 \frac{cal}{^\circ C \Delta T} \right)^2 + 0^2 \right]} \right\} * 1
 \end{aligned}$$

Signal-to-Noise Ratio (S/N) and Bias, b

$$\begin{bmatrix} FR_{1a} \\ FR_{1b} \\ FR_{1c} \end{bmatrix} = [A_i] \begin{bmatrix} DP_{1a} \\ DP_{1b} \\ DP_{1c} \end{bmatrix} = \begin{bmatrix} 2.5L \\ 2.0L \\ 1.5L \end{bmatrix}$$

$$\overline{FR_1} = m = \frac{1}{n} \sum_{p=1}^n FR_1^p = \frac{1}{3} \sum (2.5 + 2.0 + 1.5) = \frac{6}{3} = 2$$

$$\sigma^2 = \text{variance} = \frac{1}{n-1} \sum_{p=1}^n (FR_1^p - \overline{FR_1})^2 = \frac{1}{2} \sum (2.5-2)^2 + (2-2)^2 + (1.5-2)^2 = \frac{1}{4}$$

$$S/N = 10 \log_{10} \left(\frac{m^2}{\sigma^2} \right) = 10 \log_{10} \left(\frac{2^2}{1/4} \right) = 12 \text{ db}$$

$$b = (FR_1)_0 - \overline{FR_1} = 2 - 2 = 0$$

$$\begin{bmatrix} FR_{2a} \\ FR_{2b} \\ FR_{2c} \end{bmatrix} = [A_i] \begin{bmatrix} DP_{2a} \\ DP_{2b} \\ DP_{2c} \end{bmatrix} = \begin{bmatrix} 90^\circ C \\ 68^\circ C \\ 65^\circ C \end{bmatrix}$$

$$\overline{FR}_2 = m = \frac{1}{n} \sum_{p=1}^n FR_2^p = \frac{1}{3} \sum (90 + 68 + 65) = 74$$

$$\sigma^2 = \text{variance} = \frac{1}{n-1} \sum_{p=1}^n (FR_2^p - \overline{FR}_2)^2 = \frac{1}{2} \sum (90-74)^2 + (68-74)^2 + (65-74)^2 = 186.5$$

$$S/N = 10 \log_{10} \left(\frac{m^2}{\sigma^2} \right) = 10 \log_{10} \left(\frac{74^2}{186.5} \right) = 14.7 \text{ db}$$

$$b = (FR_2)_0 - \overline{FR} = 60 - 74 = -14$$

$$\begin{bmatrix} FR_{3a} \\ FR_{3b} \\ FR_{3c} \end{bmatrix} = [A_i] \begin{bmatrix} DP_{3a} \\ DP_{3b} \\ DP_{3c} \end{bmatrix} = \begin{bmatrix} 6408 \text{ g} \\ 5500 \text{ g} \\ 4365 \text{ g} \end{bmatrix}$$

$$\overline{FR}_3 = m = \frac{1}{n} \sum_{p=1}^n FR_3^p = \frac{1}{3} \sum (6408 + 5500 + 4365) = 5424 \text{ g}$$

$$\sigma^2 = \text{variance} = \frac{1}{n-1} \sum_{p=1}^n (FR_3^p - \overline{FR}_3)^2 = \frac{1}{2} \sum (6408 - 5424)^2 + (5500 - 5424)^2 + (4365 - 5424)^2 = 1,048,000$$

$$S/N = 10 \log_{10} \left(\frac{m^2}{\sigma^2} \right) = 10 \log_{10} \left(\frac{5424^2}{1,048,000} \right) = 14.5 \text{ db}$$

$$b = (FR_3)_0 - \overline{FR}_3 = 5500 - 5424 = 76$$

Summary Table

	FR ₁	FR ₂	FR ₃
m	2	74	5424
b	0	-14	76
S/N	12 db	14.7 db	14.5 db
R	FR ₁ :FR ₂ =0.9998 FR ₁ :FR ₃ =1	FR ₂ :FR ₃ =1	
S	<1	<1	<1

$$\begin{Bmatrix} FR_1 \\ FR_2 \\ FR_3 \end{Bmatrix} = \begin{bmatrix} A_{11} & A_{12} & A_{13} \\ A_{21} & A_{22} & A_{23} \\ A_{31} & A_{32} & A_{33} \end{bmatrix} \begin{Bmatrix} DP_1 \\ DP_2 \\ DP_3 \end{Bmatrix}$$

$$Ideality = \frac{\sum F_u}{\sum (F_h + \text{cost})} = \frac{(A_{11} + A_{22} + A_{33})}{(A_{12} + A_{13} + A_{21} + A_{23} + A_{31} + A_{32}) + \text{cost}(DP_1 + DP_2 + DP_3)}$$

Capability

$$C_{p_{DP1}} = \frac{USL - LSL}{6\sigma} = \frac{DP_{1a} - DP_{1c}}{6\sigma};$$

$$C_{p_{DP2}} = \frac{USL - LSL}{6\sigma} = \frac{DP_{2a} - DP_{2c}}{6\sigma};$$

$$C_{p_{DP3}} = \frac{USL - LSL}{6\sigma} = \frac{DP_{3a} - DP_{3c}}{6\sigma};$$

$$C_{system} = \min(C_{p_{DP1}}, C_{p_{DP2}}, C_{p_{DP3}})$$

$$\sigma^2 = \text{variance} = \frac{1}{n-1} \sum_{p=1}^n (FR_j^p - \bar{FR}_i)^2$$

$$\sigma_{FR1}^2 = \frac{1}{2} \left[(A_{11a} DP_1 - \bar{FR}_1)^2 + (A_{11b} DP_1 - \bar{FR}_1)^2 + (A_{11c} DP_1 - \bar{FR}_1)^2 \right]$$

where

$$\bar{FR}_1 = \frac{1}{2} (FR_{1a} + FR_{1b} + FR_{1c})$$

$$\sigma_{FR2}^2 = \frac{1}{2} \left[(A_{22a} DP_2 - \bar{FR}_2)^2 + (A_{22b} DP_2 - \bar{FR}_2)^2 + (A_{22c} DP_2 - \bar{FR}_2)^2 \right]$$

where

$$\bar{FR}_2 = \frac{1}{2} (FR_{2a} + FR_{2b} + FR_{2c})$$

$$\sigma_{FR3}^2 = \frac{1}{2} \left[(A_{33a} DP_3 - \bar{FR}_3)^2 + (A_{33b} DP_3 - \bar{FR}_3)^2 + (A_{33c} DP_3 - \bar{FR}_3)^2 \right]$$

where

$$\bar{FR}_3 = \frac{1}{2} (FR_{3a} + FR_{3b} + FR_{3c})$$

$$S = \prod_{j=1}^n \frac{|A_{jj}|}{\left(\sum_{k=1}^n A_{kj}^2\right)^{1/2}} = \left(\frac{|A_{11}|}{(A_{11}^2 + A_{21}^2 + A_{31}^2)^{1/2}}\right) \left(\frac{|A_{22}|}{(A_{21}^2 + A_{22}^2 + A_{23}^2)^{1/2}}\right) \left(\frac{|A_{33}|}{(A_{31}^2 + A_{32}^2 + A_{33}^2)^{1/2}}\right)$$

$$R_{12} = \cos(\alpha - \alpha'); \quad \alpha = \tan^{-1}\left(\frac{-A_{12}}{A_{22}}\right); \quad \alpha' = \tan^{-1}\left(\frac{A_{21}}{A_{11}}\right)$$

$$R_{13} = \cos(\alpha - \alpha'); \quad \alpha = \tan^{-1}\left(\frac{-A_{13}}{A_{33}}\right); \quad \alpha' = \tan^{-1}\left(\frac{A_{31}}{A_{11}}\right)$$

$$R_{23} = \cos(\alpha - \alpha'); \quad \alpha = \tan^{-1}\left(\frac{-A_{23}}{A_{33}}\right); \quad \alpha' = \tan^{-1}\left(\frac{A_{32}}{A_{22}}\right)$$

$$R_{21} = \cos(\alpha - \alpha'); \quad \alpha = \tan^{-1}\left(\frac{-A_{21}}{A_{22}}\right); \quad \alpha' = \tan^{-1}\left(\frac{A_{12}}{A_{11}}\right)$$

$$R_{31} = \cos(\alpha - \alpha'); \quad \alpha = \tan^{-1}\left(\frac{-A_{31}}{A_{33}}\right); \quad \alpha' = \tan^{-1}\left(\frac{A_{13}}{A_{11}}\right)$$

$$R_{32} = \cos(\alpha - \alpha'); \quad \alpha = \tan^{-1}\left(\frac{-A_{32}}{A_{33}}\right); \quad \alpha' = \tan^{-1}\left(\frac{A_{23}}{A_{22}}\right)$$

$$b_1 = (FR_1)_0 - \frac{1}{2}(FR_{1a} + FR_{1b} + FR_{1c})$$

$$b_2 = (FR_2)_0 - \frac{1}{2}(FR_{2a} + FR_{2b} + FR_{2c})$$

$$b_3 = (FR_3)_0 - \frac{1}{2}(FR_{3a} + FR_{3b} + FR_{3c})$$

$$SNR_1 = \frac{(FR_{1a} + FR_{1b} + FR_{1c})}{\left(A_{11a} DP_1 - \frac{1}{2}(FR_{1a} + FR_{1b} + FR_{1c})\right)^2 + \left(A_{11b} DP_1 - \frac{1}{2}(FR_{1a} + FR_{1b} + FR_{1c})\right)^2 + \left(A_{11c} DP_1 - \frac{1}{2}(FR_{1a} + FR_{1b} + FR_{1c})\right)^2}$$

$$SNR_2 = \frac{(FR_{2a} + FR_{2b} + FR_{2c})}{\left(A_{22a} DP_2 - \frac{1}{2}(FR_{2a} + FR_{2b} + FR_{2c})\right)^2 + \left(A_{22b} DP_2 - \frac{1}{2}(FR_{2a} + FR_{2b} + FR_{2c})\right)^2 + \left(A_{22c} DP_2 - \frac{1}{2}(FR_{2a} + FR_{2b} + FR_{2c})\right)^2}$$

$$SNR_3 = \frac{(FR_{3a} + FR_{3b} + FR_{3c})}{\left(A_{33a} DP_3 - \frac{1}{2}(FR_{3a} + FR_{3b} + FR_{3c})\right)^2 + \left(A_{33b} DP_3 - \frac{1}{2}(FR_{3a} + FR_{3b} + FR_{3c})\right)^2 + \left(A_{33c} DP_3 - \frac{1}{2}(FR_{3a} + FR_{3b} + FR_{3c})\right)^2}$$

Combining Ideality and Reangularity

$$Ideality = \frac{\sum F_u}{\sum (F_h + \text{cost})} = \frac{(A_{11} + A_{22} + A_{33})}{\left(\frac{1}{R_{12}} + \frac{1}{R_{13}} + \frac{1}{R_{21}} + \frac{1}{R_{23}} + \frac{1}{R_{31}} + \frac{1}{R_{32}} \right) + \text{cost}(DP_1 + DP_2 + DP_3)}$$